

Orten'zia, Petals of *Light*.

design Bruno Rainaldi
terzani.com

TERZANI
LA LUCE PENSATA





Body |

Type |
Battery operated table lamp

Materials |
Metal

Finishes | Code

-  Silver
OM50B G7 C8
-  Gold
OM50B H8 C8

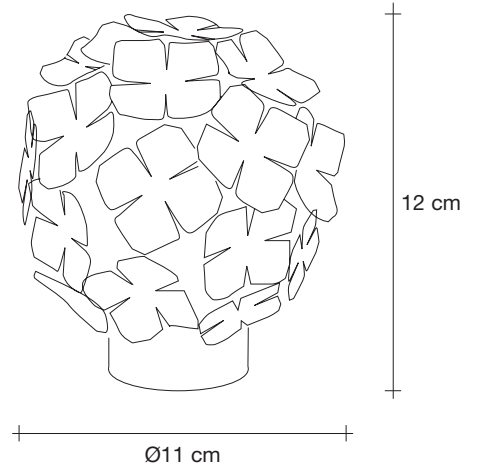

Gift packaging included



Light Source |

 LED integrated
0,3W
15 lm

 Not Dimmable

Base |

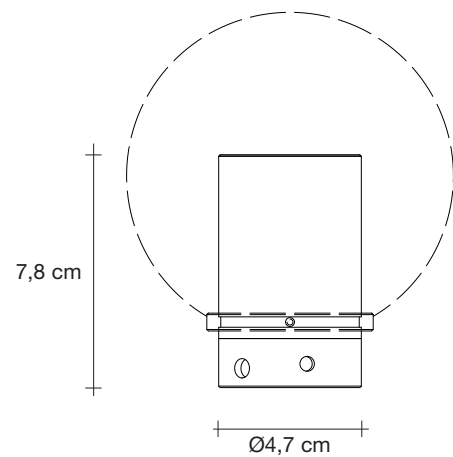

Recalling the natural beauty of a flower, Orten'zia hand-soldered "petals" emanate a unique glow, immersing the entire room in a glimmering light. An organic radiance is created through light and shadow, planting a garden within the room. Available in either nickel or gold plated, the orten'zia's elegant form complements its dramatic light. Design Bruno Rainaldi.



12,5cm x 12,5cm x 18cm

Orten'zia, Petals of *Light*.

design Bruno Rainaldi
terzani.com

TERZANI
LA LUCE PENSATA



Type |
Table lamp

Materials |
Metal

Finishes | Code

 Nickel
OM41B E7 C8

 Gold
OM41B H8 C8

Body |

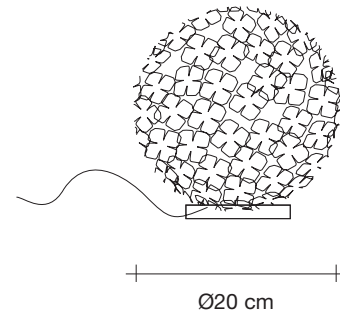

Light Source |
220-240V ~ 50/60Hz

 HALOGEN
42W E14

or

 LED
4W E14

 Integrated dimmer

Base |

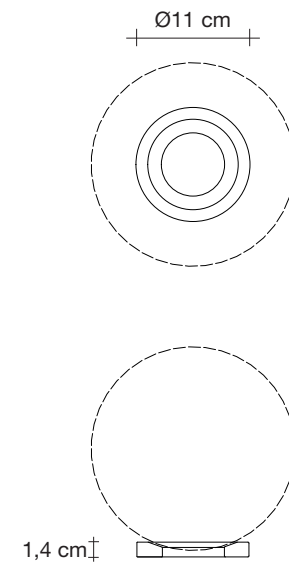

Recalling the natural beauty of a flower, Orten'zia hand-soldered "petals" emanate a unique glow, immersing the entire room in a glimmering light. An organic radiance is created through light and shadow, planting a garden within the room. Available in either nickel or gold plated, the orten'zia's elegant form complements its dramatic light. Design Bruno Rainaldi.



30cm x 30cm x 30cm